



Technical Reference

Stand Alone Operation – Capstone Model C30 and C60

Introduction

This document presents information on operating the Capstone MicroTurbine in Stand Alone mode. Stand Alone mode allows power generation at locations where there is either no electric utility service or where backup power is desired when the electric utility is unavailable. For Stand Alone operation, the voltage and frequency of the MicroTurbine are set to meet load requirements. The MicroTurbine behaves as a voltage source that always follows the power requirements of the load, (i.e., the output power is determined by the actual current draw demanded by the connected loads).

The MicroTurbine in Stand Alone mode utilizes a large on-board battery pack to power connected loads when no electric grid utility is available. The battery provides energy for starting the MicroTurbine, and once idle conditions are reached, provides an electrical buffer for sudden increases or decreases in load. During operation, the battery also provides energy for supporting power draw while the MicroTurbine increases speed to provide the necessary power. In addition, it serves as a buffer to absorb energy during a loss of load while the MicroTurbine decelerates to produce less power. During MicroTurbine shutdown, the battery may be placed in sleep mode to minimize drain and preserve battery charge. Management of the battery and its state-of-charge is automatic during MicroTurbine operation.

Features

Stand Alone capabilities include a *Soft Start* function, which allows the MicroTurbine to begin exporting power at less than nominal voltage and frequency, and then linearly increases voltage and frequency to nominal levels over a period of time. This Soft Start feature can assist in starting loads with large in-rush currents. To meet output power requirements automatically, the system can be configured in *Auto Load* mode. Auto Load ensures that the MicroTurbine closes the output contactor to immediately produce the required output power once minimum engine load speed is reached.

Power Specifications

The electrical output is user-adjustable from 150 to 480 volts AC, 10 to 60 Hz. The current in each phase may be continuous and need not be balanced, as long as electrical current limits are respected. For complete electrical performance ratings, see Model C30 and Model C60 Electrical Technical Reference (410000 and 410001). For details on electrical wiring requirements, see the Electrical Interconnection Technical Reference (410009).

Other Modes

The MicroTurbine can be configured in two other modes of operation: Grid Connect, and Dual Mode. Grid Connect configures the MicroTurbine in parallel with the local electric utility grid to reduce utility electric demand during peak load periods. Dual mode combines both Stand Alone and Grid Connect modes so that the MicroTurbine is able to maximize power availability, utilizing the grid when available and operating in Stand Alone during a utility outage. Refer to the Grid Connect Operation Technical Reference (410027) and Dual Mode Controller Technical Reference (410039) for details.

Configuring Stand Alone Operating Mode

Overview

Stand Alone mode utilizes an on-board battery to supply external loads with power. To enable Stand Alone mode operation:

- ❑ Electrically close the Stand Alone contacts in the communications bay (see *Stand Alone Interlock* section)
- ❑ Set the battery isolation switch to ON (See *Battery Isolation Switch* section).
- ❑ Wake-up the MicroTurbine (See *Waking a Stand Alone MicroTurbine* section).
- ❑ Configure the software for Stand Alone operation for one of two modes of access:
 - User input – through the local display panel or CRMS
 - Remote input – CRMS through either the RS-232 User or Maintenance port
- ❑ (Optional) Select Auto Restart mode to automatically attempt a restart after an incident-driven fault (See *Auto Restart Dispatch Mode* section).
- ❑ (Optional) Select Auto Load mode to automatically close the output contactor once the system has started and is ready to load (See *Auto Load Dispatch Mode* section).
- ❑ (Optional) Select MultiPac mode to combine MicroTurbine power in series with any of the above dispatch modes (See *MultiPac Power Dispatch Mode* section).
- ❑ Start MicroTurbine electrical operation (See *Starting a Stand Alone System*).
- ❑ Begin supplying power to external devices (See *Activating Stand Alone Power Output* section).

Hardware Configuration

Contact Terminal Locations

NOTE The MicroTurbine will not operate in Stand Alone mode if grid power is present on the output terminals (or another voltage source) is connected to any phase.

The User Connection Board (UCB) located in the communications bay allows for low-resistance closed-loop circuit connections on 5-volt dry circuit contact terminals. Contact terminal connections are internal to the MicroTurbine, with the exception of external switch contacts, which may be remotely connected to any external device (e.g., PLC or switch):

- Battery Wake-up – Provides momentary (0.1 to 2 sec) signal closure to wake-up the battery. Permanent contact closure (>2 sec) WILL COMPLETELY discharge the battery ! (See “Waking a Stand Alone MicroTurbine”)
- Stand Alone Interlock – Establishes the Stand Alone mode of operation
- External Switch – Enables hardware interlock for remote turbine communication. Software settings must also be established (see “Configuring the Dispatch Modes”)

Figures 1 and 2 show the Model C30 and Model C60 contact terminal locations.

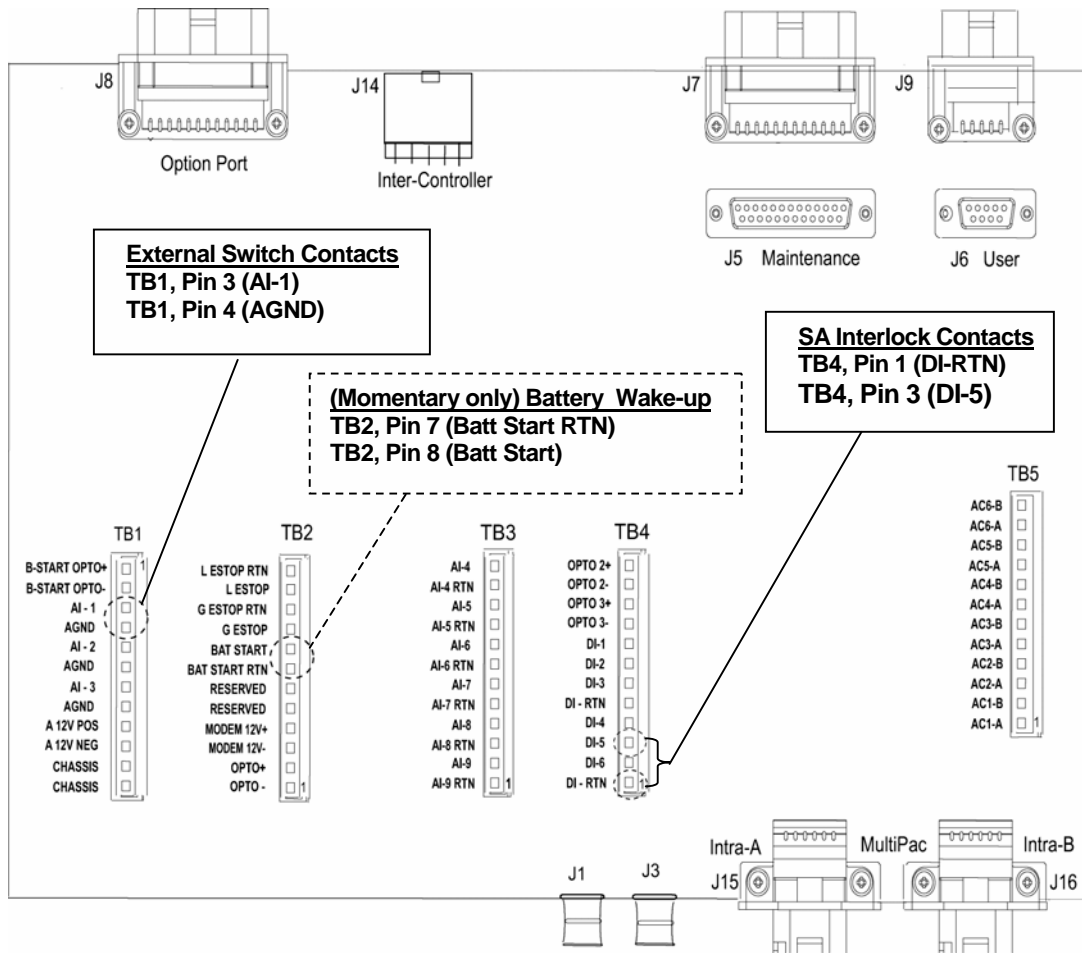

Figure 1. Stand Alone Contact Terminal Locations (Model C30)

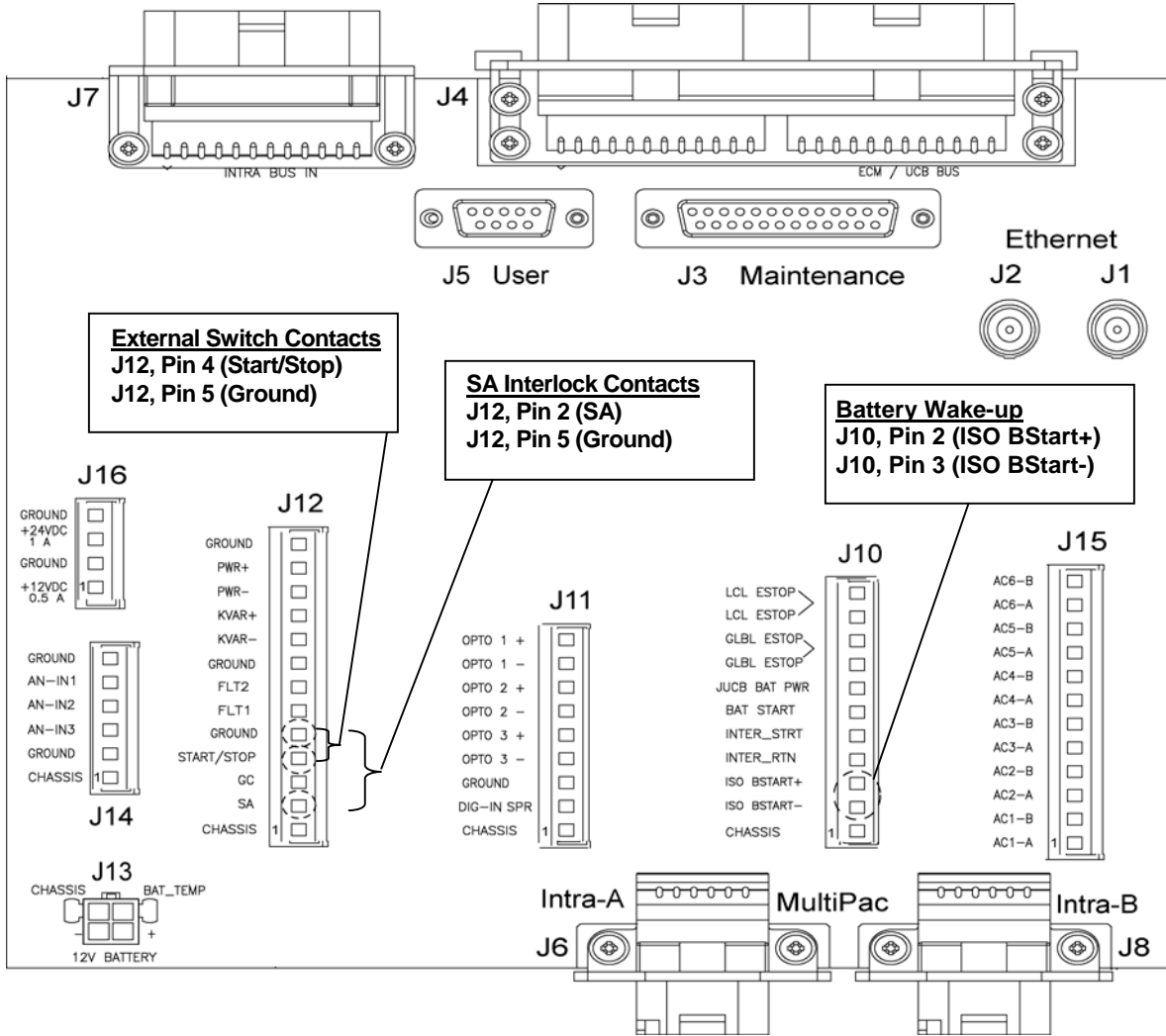

Figure 2. Stand Alone Contact Terminal Locations (Model C60)

Battery Isolation Switch

A battery isolation switch to disable the MicroTurbine for service or transport is located behind the lower kick panel on the C30 standard package, at the rear of C30 industrial package or inside the front door of the C60 package. Set the switch to ON for system operation.

UCB Battery (C30 vs. C60)

Both C30 and C60 systems utilize a separate battery located in the UCB connection bay for remote system battery wake-up functionality.

The Model C60 contains a +12VDC battery (see Figure 3), which is recharged automatically when the MicroTurbine senses a low state-of-charge. The battery replacement interval is 24 months (refer to Scheduled Maintenance Work Instructions (440000)). However, with the modem connected and the MicroTurbine in Standby mode, the UCB battery will drain in five to seven days. Disconnect the modem or turn power OFF from the modem to extend the battery life.

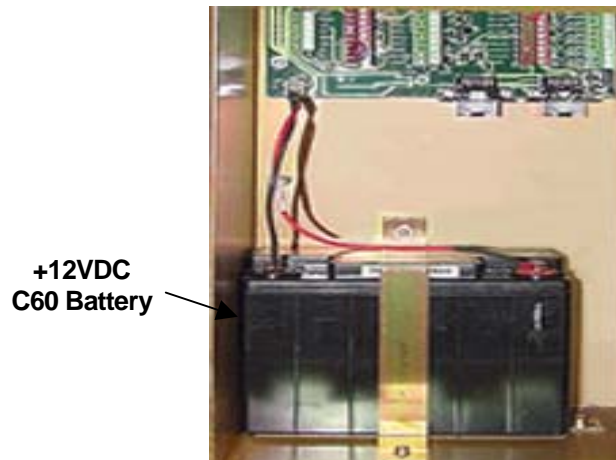

Figure 3. Model C60 UCB Battery (+12VDC)

The Model C30 contains a +3VDC lithium battery (see Figure 4) located on the PCB that cannot be recharged and must be replaced. Refer to the Scheduled Maintenance Work Instructions (440000) for details.

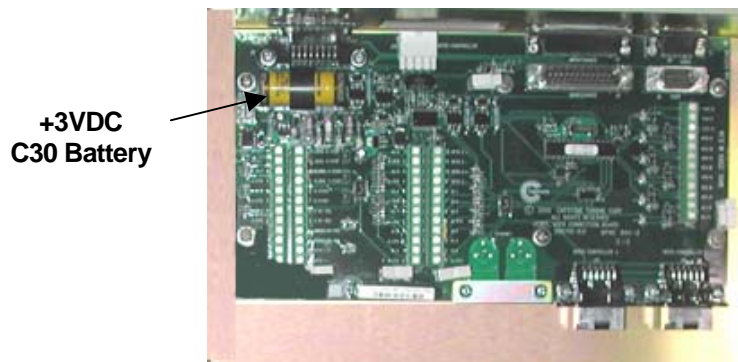

Figure 4. Model C30 UCB Battery (+3VDC)

Stand Alone Operation

System Sleep in Stand Alone Mode

The MicroTurbine enters Sleep Mode to conserve battery power during prolonged periods of inactivity. This reduction in battery draw can significantly extend the MicroTurbine battery charge. Sleep Mode inactivity time can be adjusted, and this feature may be configured to activate automatically.

NOTE	If the battery isolation switch is set to ON, and the display panel is dark, the system is most likely in Sleep Mode.
-------------	---

To manually place the MicroTurbine in a sleep mode:

- CRMS: Not Applicable
- Display panel: Pressing the INTERLOCK and DISABLE buttons simultaneously after the MicroTurbine has transitioned to Standby mode also results in system sleep.

Waking a Stand Alone MicroTurbine

If the Stand Alone system is in Sleep Mode, pressing the BATT START button at the far left of the Display Panel (for less than or equal to 2 seconds) will wake it up. If using remote communication, the modem ring indicator will wake up a sleeping Stand Alone system.

Alternately, momentarily closing the battery start contacts in the communications bay will also wake up the system. This must be a momentary closure of 0.1 to 2.0 seconds only, as permanent closure of these UCB wakeup contacts will completely discharge the battery. See Figures 1 and 2 for location of battery start momentary contacts on the UCB.

Stand Alone Mode Enable

NOTE	If the Stand Alone Interlock is open, the system will accept the command but post an <i>SA Interlock Fault</i> . If no battery is detected, a <i>No Battery Fault</i> is reported.
-------------	--

The MicroTurbine can be configured to recognize Stand Alone mode using the display panel or CRMS. To configure the MicroTurbine to operate in Stand Alone mode:

- CRMS: Select *Settings > Control Settings*, and set Power Connect slider to Stand Alone.
- Display panel: Enter the user password (default is **87712370**), and navigate as follows - *System Data > System Configuration > Power Connect*. Select Stand Alone mode, and then press the ACCEPT button.

Starting a Stand Alone System

After the BATT START wakes the MicroTurbine, the Stand Alone system may be started. A Start can be performed one of three ways: 1) Display panel, 2) CRMS or 3) A signal received through external switch contacts on the UCB. For external switch contacts to work properly, wiring connections to the attached device must be established before MicroTurbine software is configured to enable the switch (see “*Configuring the Dispatch Modes – External Switch*”)

- CRMS: From the main panel, click on the Start button.
- Display panel: Press and hold the INTERLOCK and START buttons simultaneously.

Activating Stand Alone Power Output

The system will transition to produce output power in the Load state (closes output contactor) when battery voltage and base battery state-of-charge reaches at least 60 percent. To enable Stand Alone power output:

- CRMS: From the main panel, click on the Power ENABLE button.
- Display panel: Press and hold the INTERLOCK and ENABLE buttons simultaneously.

This signal may be automated with the Auto Load software feature. When the Auto Load dispatch mode is enabled, it automatically issues an Enable command when the system is ready to support the connected loads.

De-activating Stand Alone Power Output

The system can be commanded to manually deactivate output power (open output contactor) and return to the Run state where it will remain operating with fuel. To deactivate Stand Alone power output:

- CRMS: From the main panel, click on the red DISABLE button.
- Display panel: Press and hold the INTERLOCK and DISABLE buttons simultaneously.

Once an output power disable command has been given, the system must be manually commanded to again deliver output power, even if the Auto Load software feature had been previously enabled.

Stopping Stand Alone Operation

The MicroTurbine immediately ceases supplying output power (output contactor opens) when a system STOP or OFF command is issued, or when a severity level 3 fault (other than a flameout) occurs. An explicit OFF command will override any dispatch mode settings, and is stored by the system. A system OFF first disables power output and transitions to the Recharge state. Then, the system continues operating with fuel to charge the battery to 90-95 percent state-of-charge, which can take up to 20 minutes. Finally, the MicroTurbine shutdown process initiates a cooldown period, which can last up to 10 minutes.

To halt MicroTurbine operation:

- CRMS: From the main panel, click on the red STOP button.
- Display panel: Press and hold the INTERLOCK and STOP buttons simultaneously.

Initiating an Emergency Stop

WARNING	Repeated use of the optional Emergency Stop switch will result in damage to the MicroTurbine. Use only in emergency situations.
----------------	---

If an optional emergency stop (E-stop) has been installed, the E-stop switch may be activated. Activating E-stop immediately shuts off the fuel and electrical output. This causes the compressor bypass valve to open, venting the compressed air out of the MicroTurbine and causing it to coast to a stop. After an emergency stop, power to the MicroTurbine must be turned off for 30 seconds before a restart can be attempted. Emergency stops should NEVER be used for routine shutdowns. Emergency stops increase stress on the system components and will result in reduced service life of the MicroTurbine.

System States

Stand Alone mode passes through a set of system states during a normal cycle. These states are described in the section below. A simple block diagram illustrating Stand Alone system states is shown in Figure 5.

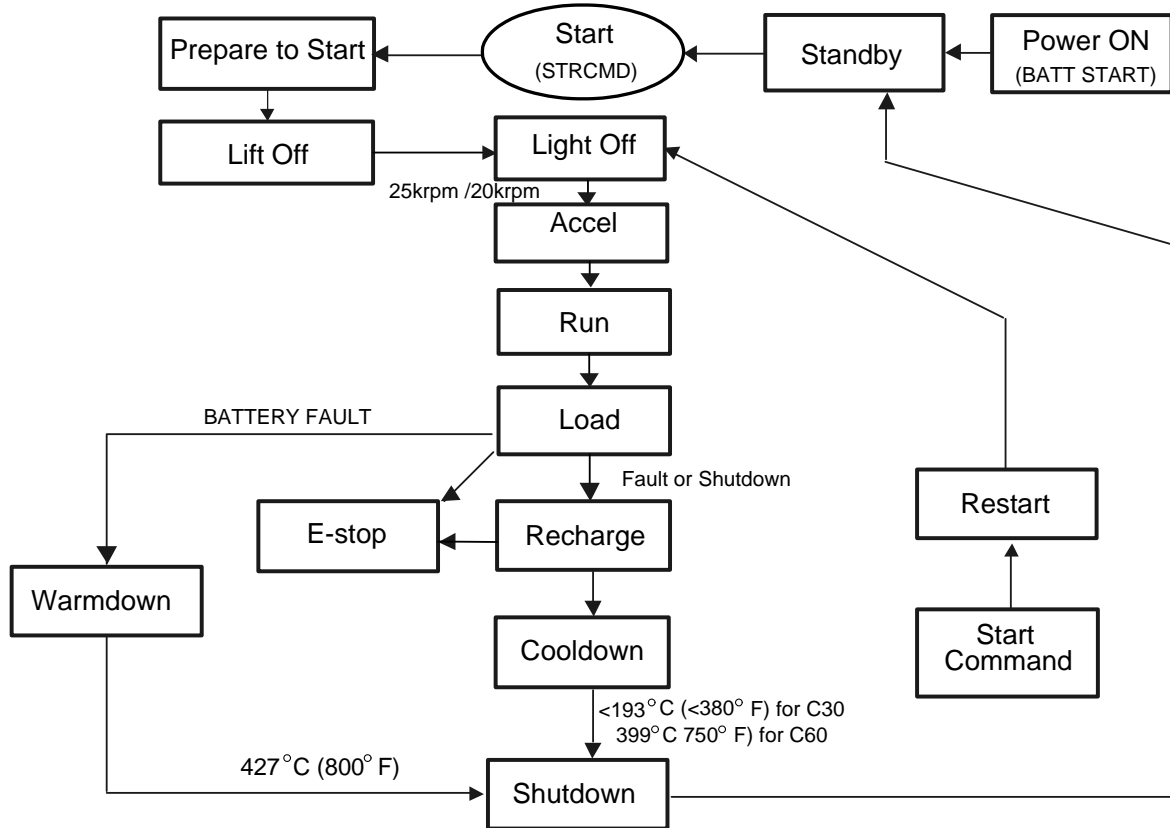

Figure 5. System State Flow Diagram

Power ON

As the MicroTurbine is powered on through a battery wake up signal (see “*Waking a Stand Alone MicroTurbine*”), the following events occur:

- The battery breaker is closed
- Wake-up signal is provided
- UCB battery provides voltage through Intra harness to battery controller control board
- Battery controller precharge signal provides battery voltage to BCT (C30)/BCM (C60)
 - C30: Precharge supply voltage provides 13.8 VDC to the BCT control board. Supply voltage is back fed through the Intra harness to the DPC control board. DC bus voltage remains at 0 VDC.
 - C60: Provides battery voltage to BCM power board. DC bus voltage is precharged to battery voltage bringing Power Distribution Module 25.4 VDC supply to ECM control board.
- Read and verify personality module (PM) data

- Verify software compatibility to ensure the correct software for installed components
- Lock communication with display panel, battery controller and fuel devices

Standby

Idle state waiting for a Start command. Battery pack provides power to the MicroTurbine controller internal power supply.

Prepare to Start

When a Start command is issued, the software transitions to the “Prepare to Start” state. This state is characterized by the following events:

- Battery voltage must be greater than 200 VDC to support Start
- Turn on the battery controller fans
- C30: Battery controller precharges DC bus to battery voltage
- Turn on power electronics fans
- Close battery contactor to bring DC bus voltage to 760VDC
- Check that communication with the fuel device has been established
- (Liquid fuel only) Liquid fuel drain opens if TET < 149° C (300° F) to remove any fuel remaining in the recuperator from prior start attempts (Liquid fuel vaporizes > 300° F)

Lift Off

Voltage and current are applied from the battery pack to the permanent magnet generator to provide torque for rotating the engine components.

- In the Model C30, rotate the generator up to 25krpm
- In the Model C60, rotate the generator up to 20krpm

Light Off

This state is characterized by air-fuel mixture combustion.

The following events occur:

- (Liquid fuel only) Liquid fuel drain closes for operation
- Turn on Intra A power - controls fuel shut off device and solenoids which allow fuel flow into the system. Intra C is turned on for RFC.
- Turn the fuel devices ON (Includes RFC air-assist device for liquid fuel systems)
- Power is applied to the igniter through the spark exciter solenoid
- Enable fuel shutoff and injector solenoids
- Increase fuel flow with the igniter on until an increase in TET is detected. If this increase is not detected within 30 seconds, a 6006 “FAIL TO LIGHT” fault is declared.

Accel

This state is characterized by ramped generator acceleration. The following events occur:

- Turn off spark exciter solenoid/igniter
- Ramp speed and fuel flow to maintain combustion, while increasing generator speed to 45krpm

Run

This state is characterized by the system delivering 0 kW output while the output contactor remains closed. The turbine will operate with fuel at 45 krpm for up to one minute to warm up engine components and remain in the Run state after the warm up is complete until a Power Enable signal is received. This signal may be automated using the Auto Load feature.

After the Power Enable signal is issued either manually or through Auto Load, the system may remain in the Run state operating at higher speeds and supplying power to the battery pack until the state-of-charge (SOC) of the battery is greater than 60%. This additional time ensures that the battery pack will be able to support any transients when the output contactor is closed.

Load

This state is characterized by the output contactor closing to export power to connected loads. When the Power Enable signal is provided, control transitions to the Load State. The Power Disable signal may be provided to disengage loads and transition back to the Run state.

Additional power may be produced by the engine into the battery pack to maintain the state-of-charge at 80% nominally for operation. The system remains in the Load state until a fault occurs or a stop command is given. The system transitions to Recharge state before entering Cooldown.

The following events occur:

- Speed varies from 45 to 96 krpm to meet power demand
 - TET nominally 1240° F at 45 krpm to 1100° F at 85 krpm and above (Model C30)
 - TET nominally 1175° F for full speed range (Model C60)
 - Temperatures may be reduced with decreasing ambient temperature
- Number of injectors used increases with power output

Recharge

The output contactor is opened disengaging loads while the engine remains operating with fuel. Speed is reduced to supply only power necessary to recharge battery pack to 90-95 percent. This process may take up to 20 minutes. The Recharge state provides the necessary charge required for Cooldown and subsequent Start. The state may be aborted by issuing a Recharge Disable command (system tracks the number of aborted recharges) since normal battery maintenance is not yet completed.

Cooldown

After a fuel fault or the completion of recharge, the system enters the Cooldown state.

The following events occur:

- The output contactor is opened
- Electrical fuel shutoff and fuel solenoids are closed so fuel no longer flows
- A purge of a liquid fuel system with air assist occurs to clear fuel out of the fuel lines through the injectors (if required)
- Intra A power is turned off
- Speed is reduced to Cooldown speed
 - Cooldown at 45 krpm (Model C30)
 - Cooldown at 50 krpm (Model C60)
- Operate at Cooldown speed providing airflow over engine components until TET reaches 193° C (380° F) for the C30 and 399° C (750° F) for C60.
 - A timed shutdown occurs if a 3004 “BOTH TET” fault occurs

Shutdown

When the Cooldown TET temperatures are reached, the software transitions to the Shutdown state.

The following events occur:

- Stop generator
- Turn off fans
- Return to Standby conditions

Warmdown

This state is characterized by a system fault or abnormal user shutdown. The output and battery contactors are opened immediately and therefore battery power is not available to support Cooldown. The dump valve is pulsed to control speed - allowing airflow for cooling, while preventing engine over speed conditions. As heat is removed from the recuperator, the engine will coast to a stop.

The following events occur:

- Power production is ceased
 - Output and battery contactor are opened
- The fuel solenoids are closed
 - Intra A power is off
 - Intra C power is off (RFC)
- Energy produced while the engine decelerates is dissipated to the brake resistor
- Enter fault state at 427° C (800° F) TET

E-Stop Shutdown

This state is characterized by a user-initiated effort to halt MicroTurbine operation immediately and IS NOT RECOMMENDED. E-Stop shutdowns provide no cooling to the engine components and the engine coasts to a stop, causing wear to the bearings. The number of emergency stops is tracked by the software and may void the warranty should engine failure occur.

The following events occur:

- Power export ceases immediately
 - Output contactor opens
- The fuel solenoids are closed
 - Intra A power is Off
 - Intra C power is Off (RFC)
- Dump valve opens to remove air flow from engine preventing engine over speed conditions
- Rotor coasts to a stop

Configuring the Dispatch Modes

Dispatch modes take advantage of the special capabilities and special features designed into the Stand Alone mode. In most configurations, these commands require a password, and are entirely automated. The paragraphs below describe the dispatch modes.

Manual Dispatch (Default)

The Manual Dispatch mode is the default mode for a newly shipped MicroTurbine. Manual Dispatch mode allows the MicroTurbine to be commanded on to its default power settings.

- CRMS: Select *Settings > User Connection Bay Settings*, and set the Start Input slider to User Start Priority (Mode 0). Then, return to the main menu and click on the START button, and click on the ENABLE button.
- Display panel: Navigate as follows - *System Data > System Configuration > Start Input*, and select the “User” option. Press the INTERLOCK and START buttons simultaneously. Wait until the MicroTurbine enters the Run state, and then press the INTERLOCK and ENABLE buttons simultaneously.

System Configuration	Parameter Description	Parameter Value	Default
Start Input <option>	Allows user the option to select local/remote mode of control.	User Remote (UCB) GC User/SA Remote SA User/GC Remote	User

External Switch

The External Switch mode allows an external signal to control the START/STOP status of the MicroTurbine at the output power level for the connected load. Figures 1 and 2 show the location of the UCB contact terminals required to enable the external switch.

Software may be configured to recognize the external switch as follows:

- CRMS: From the menu, select *Settings > User Connection Bay Settings*, and set the Start Input slider to Remote Start Priority (Mode 1).
- Display panel: Navigate as follows - *System Data > System Configuration > Start Input*, and select the “Remote” option.

Auto Restart

The MicroTurbine system can normally be restarted after a shutdown, while the battery recharges, or during the Cooldown period before the speed of the MicroTurbine reaches zero. This allows for faster power output and reduced bearing wear. If Auto Restart is ON, the system will attempt to restart after most system shutdown modes. Enabling Auto Restart increases system availability and is recommended by Capstone.

To configure the software for Auto Restart:

- CRMS: From the menu, select *Settings > Control Settings*, and then set Auto Restart to ENABLE. Then, if a time delay is required before restarting the MicroTurbine, enter the delay time in the *Auto Restart Delay - Standalone* field.
- Display panel: Navigate as follows - *System Data > System Configuration > Auto Restart*, and select ON. To enter the delay time, select *Stand Alone > Restart Delay*.

System Configuration	Parameter Description	Parameter Value	Default
Auto Restart <No/Yes>	Allows the system to restart itself after a electric utility (grid) interrupt	No Yes	No

Stand Alone Menu	Parameter Description	Parameter Value	Default
Restart Delay <Min>	Sets the time period after Restart that MicroTurbine powers up.	0 – 60 min	0

Auto Load

The Auto Load <Yes/No> option allows the user to enable the MicroTurbine to automatically close the output contactor once the system has started and is ready to load. A <Yes> setting automatically makes power available to match the load demand. A <No> setting requires the user to manually press INTERLOCK and ENABLE to allow the MicroTurbine to produce power to meet the load demand. The Auto Load feature should be enabled to have the contactor automatically close when Auto Restart is enabled and a restart fault occurs.

To configure the software for Auto Load:

- CRMS: From the menu, select *Settings > Stand Alone Voltage and Frequency*, and then set the Auto Enable Power toggle to ON.
- Display panel: Navigate as follows - *System Data > Auto Load*, and select Enable.

System Data Menu	Parameter Description	Parameter Value	Default
Auto Load <Yes/No>	Enables/disables the presence of output voltage when the Load state is achieved.	0 = No 1 = Yes	No

MultiPac Power

MicroTurbines can be installed in groups of up to 20 units (100 units with the optional Capstone PowerServer) to operate as a single power generation source. MultiPac capability features a single control point and synchronous voltage and frequency output for all units. Individual MicroTurbines share power and load on both a dynamic and steady state basis.

For Stand Alone mode, the output power from units in the MultiPac is synchronized. Systems will remain in the Run state with their contactors open until enough units are available to meet minimum power capabilities, at which time all output contactors close. If minimum power is not met within MultiPac power time, the units will fault and shutdown, preventing prolonged operation with fuel and no power output. Refer to the MultiPac Technical Reference (410032) for more details on MultiPac configuration and operational requirements.

To configure MultiPac power requirements:

- CRMS: From the menu, select *Settings > MultiPac Settings*, enter the Turbine number in the adjacent field (Master = 1) and set the toggle to Enable. In the expanded window for the master turbine, enter the minimum MultiPac power (kW) and power timeout (sec).
- Display panel: Navigate as follows - *Stand Alone > System Configuration > Turbine Number*, and enter a unique turbine identifier. Then navigate to *System Data > System Configuration > MultiPac*, and select Enable.

To enter the MP Min Power, navigate as follows: *Stand Alone > MultiPac Power* and enter the minimum MultiPac power (kW) and minimum power timeout (sec).

System Configuration	Parameter Description	Parameter Value	Default
Turbine Number <Number>	Select a unique numerical identifier for MultiPac configuration	1 – 20	1
MultiPac <Enable/Disable>	Enables or disables MultiPac configuration	0 = Disable 1 = Enable	0 (Disabled)

Stand Alone Menu	Parameter Description	Parameter Value	Default
MultiPac Min Power <kW> <Sec>	Minimum power requirement that must be satisfied before MultiPac Load operation will commence in Stand Alone mode. Master turbine declares a fault if the minimum time setting has been exceeded.	0 to 2000000 kW 0 – 3600 sec	0 0

Battery Charge Management

After a Start command, the system leaves the Standby state to power up MicroTurbine components to operational levels before transitioning to the *Run state*, where battery charging may again occur. Once started, the MicroTurbine will not advance to the *Load state* until the battery state-of-charge is at least 60 percent (only occurs under conditions of poor maintenance, multiple subsequent fault cycles or end of battery life). After this state is achieved, the output contactor is closed and the MicroTurbine begins producing power for connected loads.

The MicroTurbine system is designed to keep the battery 80 percent charged during *Load state* operation to allow for sourcing and sinking of power transients, and to maintain an operating state-of-charge. If a user-initiated STOP is performed, the system immediately enters the recharge state, bringing the battery to over 90 percent state-of-charge before entering the *Cooldown state*. Normally, the system will take approximately twenty (20) minutes to recharge the battery following a STOP command. On transition to *Cooldown*, fuel is commanded off and the MicroTurbine spins down, but remains rotating to provide airflow over engine components for cooling. After *Cooldown* is complete, the MicroTurbine enters a short *Shutdown state* before finally entering the *Standby state*. No battery charging is performed while in *Standby*.

If the system is not commanded ON during a user-selectable time period, the system will automatically enter a minimum battery drain state called *Sleep state*. This time period is called the Auto Sleep Time. Putting the battery in *Sleep state* can preserve battery charge for up to six months (life is based on ambient temperatures).

To adjust the Auto Sleep Time period, enter the user password, and navigate to the *Battery Management > Auto Sleep Time* submenu. Sleep time is designed so that an inactive MicroTurbine will remain in the *Standby state*, before automatically entering the *Sleep state*, to sustain minimal power draw and maintain battery life. The timer is adjustable up to 24 hours but should be set to a minimum level to preserve battery life. In some ambient temperatures, the battery can drain in much less than 24 hours.

Auto sleep time may be configured using the display panel or CRMS:

- CRMS: select: *Settings > Battery Management*, enter the sleep time in hours.
- Display panel: Navigate as follows - *Battery Management > Auto Sleep Time*, then enter the value in hours.

Battery Management	Parameter Description	Parameter Value	Default
Auto Sleep Time <Hours>	Configures time that MicroTurbine remains in Standby before entering Sleep state	0.1 – 24.0 hrs	1.0

If the MicroTurbine is in *Sleep* or *Standby state*, there is a parasitic load that will greatly reduce the allowable storage time. In addition, battery packs stored for extended periods will become discharged and will require periodic charging. However, if this interval is excessive, the battery pack may have permanently reduced capacity and could require replacement. The MicroTurbine Standard Maintenance Schedule Work Instruction (440000) provides battery recharge intervals for *Sleep* or *Standby states*, as well as replacement intervals. The Battery Performance Technical Reference (410044) provides detailed data on life expectancy.

If the MicroTurbine is in operation, the automatic shutdown recharge and equalization charge will normally be sufficient to sustain the battery pack life. If the MicroTurbine cannot be operated, a grid connect idle recharge may be used. Alternatively, contact Capstone Technical Support for details on the optional Capstone External Battery Charger.

The system may be configured to perform a battery recharge AUTOMATICALLY for a 4-hour period when the MicroTurbine is in Grid Connect Standby state.

Using CRMS:

- Select *Settings > Battery Management*, and set the *Auto Charge* slider to Enable. Then, using the Time Before Next Charge, enter the desired interval (in days) before recharge.

Using the Display Panel:

- Navigate as follows - *Battery Management > Auto Standby Chg*, and select Enable and press ACCEPT. Then, navigate to the *Battery Management > Grid Batt Eq Chg* to enter the desired interval (in days) before recharge.

Battery Management	Parameter Description	Parameter Value	Default
Auto Standby Chg < Disable/Enable>	Controls battery recharge when the system is in Grid Connect Standby state	0 = Disable 1 = Enable	Disable
Grid Batt Eq Chg < days>	Number of days before recharge when using Auto Standby Chg (or automatic by default if the system is in GC Load state)	7- 30 days (if using Auto Standby Chg)	30 days

Battery charging may also be initiated MANUALLY while in the Grid Connect or Stand Alone Load state or as Grid Connect Idle Recharge while in the Grid Connect Standby state.

Using CRMS:

- Select *Settings > Battery Management*, and set the *Equalization Charge* slider to Enable.

Using the Display Panel:

- To control battery recharge on the local turbine only, navigate as follows - *Battery Management > Local Batt Chg*, select Enable and then press ACCEPT.

Battery Management	Parameter Description	Parameter Value	Default
Local Batt Chg < Disable/Enable>	Controls whether the system begins to recharge the battery when the system is in Grid Connect mode Standby state, or in the Grid Connect or Stand Alone mode Load State.	0 = Disable 1 = Enable	Disable

- To control battery recharge on ALL turbines in a MultiPac system (via the master turbine), navigate as follows - *Battery Management > Global Batt Chg*, select Enable and then press ACCEPT.

Battery Management	Parameter Description	Parameter Value	Default
Global Batt Chg < Disable/Enable>	Controls battery recharge on all turbines in a MultiPac system. The command must be issued on the master turbine.	0 = Disable 1 = Enable	Disable

Equalization Charge

NOTE	Once an equalization charge has started, it will complete regardless of the day and hour of the permission set-up.
-------------	--

The MicroTurbine will perform an equalization charge cycle periodically to maintain an equal charge in all battery cells. This equalization charge may be automated or commanded manually (charges to 100% state-of-charge) and may take up to four hours. Equalization charging may be disallowed during certain hours of certain days of the week to prevent interference with dispatch schedules. See the Model C30 Electrical Technical Reference (410000) and Model C60 Electrical Technical Reference (410001) for step load capability.

The Equalization Charge submenu is configurable for each day of the week. Selecting Disable disallows the entire day. Default equates to all days active. If a charge is allowed to occur, the *First OK Hour* and *Last OK Hour* are programmed using a 24-hour clock. Once an equalization charge commences, it will run to completion. Times should be configured with the understanding that an equalization charge can take four hours.

In Stand Alone mode, the software will automatically initiate an equalization charge based on watt-hours usage of the battery pack. For full time Stand Alone operation, this occurs approximately once per week. A small amount of power produced by the MicroTurbine is provided to the battery pack to bring it up to 100 percent state-of-charge. Note that this power is not available to output loads, and the user may program allowable times for this charge to take place.

In Dual Mode configuration, the system will automatically initiate the equalization charge during the Grid Connect Load state every 7-30 days based on the Grid Batt Eq Chg days value. If an equalization charge is required, the system will initiate a battery wake up, perform the 4-hour charge, and then put the battery pack back into sleep mode. If a charge is not required, the system will put the battery into sleep mode after 15 minutes in the Grid Connect Load state. The default is that charging is allowed any time of the day. Days or times should be reduced to prevent charging from occurring during peak demand times. A minimum of one 4-hour window during MicroTurbine operating hours is required to maintain battery life.

Perform the following steps to program the allowable times for equalization charging during certain times of the week:

- CRMS: From the menu, select *Settings > Battery Management*, and toggle on the allowed days of the week. Then, select the first and last allowable hours for equalization charge.
- Display panel: Navigate as follows - *Battery Management > Equalization Charge* submenu. The first screen provides for day of week choice, the submenu screen decides whether equalization charging is or is not allowed on that day. The second submenu establishes the beginning hour is allowed for that day. The third submenu establishes the ending hour that charging is allowed.

Battery Management	Parameter Description	Parameter Value	Default
Equalization Charge <Day>	Allows user to perform a battery equalization charge at selected intervals	Mon – Sun	Mon
Charge Allowed <Disable/Enable>	Selects equalization charging by day	0 = Disable 1 = Enable	Enable
First Hour OK <Hour>	Selects first hour of charge	00 -23	00
Last Hour OK <Hour>	Selects first hour of charge	00 -23	23 (:59 implied)

Protective Relay Settings

Protective Relay settings establish voltage and frequency operating limits and associated fault protection for the MicroTurbine. Voltage and frequency setpoints may be programmed as well as associated fault protection limits. These adjustments are provided to protect common loads by disabling power production during undesired transient conditions. The settings are adjustable to allow the user to narrow or restrict the operating envelope. Protective relay settings are stored in EEPROM non-volatile memory and are not subject to power interruptions.

When a protective function initiates a shutdown, the following occurs: 1) Output power flow ceases within 100 msec. 2) The power output contactor is opened within 100 msec, disabling the MicroTurbine power output from the local load. 3) Fuel flow to the MicroTurbine stops, and 4) A warm shutdown ensues, during which control power is supplied from the MicroTurbine generator as it slows down. The warm shutdown lasts 1-2 minutes before the rotor is stopped.

Protective relay settings can be configured from the display panel or CRMS. In CRMS, from the menu, select: *Settings > Stand Alone Voltage and Frequency Settings*. In the display panel, navigate to the Stand Alone menu and select settings (see tables below).

Operating Voltage

NOTE	Below 376V, MicroTurbine power output is limited based on current limits of the electronics. Refer to the Model C30 and Model C60 Electrical Technical Reference documents for details (410000 and 410001).
-------------	---

- CRMS: From the menu, select *Settings > Stand Alone Voltage and Frequency Settings*, and enter the desired operating voltage in the Voltage V_{RMS} field.
- Display panel: Navigate as follows - *Stand Alone > Voltage*, and enter the desired operating voltage.

Stand Alone Menu	Parameter Description	Parameter Value	Default
Voltage < V_{RMS} >	Sets the operating voltage.	150 – 480 V_{RMS}	480

Under Voltage

The system will initiate a shut down if the voltage drops below this setting for a user-selected timer value. The timer value establishes the period for any phase voltage to fall below the Under Voltage limit set point.

- CRMS: From the menu, select *Settings > Stand Alone Voltage and Frequency Settings*, and enter the desired *Under Voltage* value.
- Display panel: Navigate as follows - *Stand Alone > Under Voltage*.

Stand Alone Menu	Parameter Description	Parameter Value	Default
Under Voltage < V_{RMS} > <sec>	Sets under voltage limit for shutdown if operating voltage drops below this value.	0 – 480 V_{RMS} 0.00 – 10.00 sec	428 1.9

Over Voltage

The system will initiate a shut down if the voltage rises above this setting for a user-selected timer value. Over Voltage delay establishes the period for any phase voltage to rise above the Over Voltage set point limit.

- CRMS: From the menu, select: *Settings > Stand Alone Voltage and Frequency Settings*, and enter the desired *Over Voltage* value.
- Display panel: Navigate as follows - *Stand Alone > Over Voltage*, and configure settings.

Stand Alone Menu	Parameter Description	Parameter Value	Default
Over Voltage <V _{RMS} > <sec>	Sets over voltage limit for shutdown if operating voltage exceeds this value.	528 –480 V _{RMS} 10.0 – 0.00 sec	524 1.9

Soft Start Voltage

The MicroTurbine may be configured to begin exporting power at less than nominal voltage and frequency, and then linearly ramp to nominal values over a selected time period using the Soft Start Voltage setting. The Soft Start Voltage (0 to 480 V) setting is typically used to enable the MicroTurbine to start a motor (or other loads), which cannot handle full load current immediately. This parameter differs from the Operating Voltage setting (150 to 480 V), which represents the load voltage at normal operating conditions. When the output contactor closes, the system will provide demanded current at this starting voltage and immediately begin increasing the voltage at the configured rate, up to the nominal voltage.

Ramp Rate Volts per Second establishes the rate of voltage increase. When the output contactor closes, the system will provide demanded current at the voltage established above and immediately begin increasing the voltage at this rate.

- CRMS: From the menu, select *Settings > Stand Alone Voltage and Frequency Settings*, and enter the desired *Start Voltage* and *Voltage Ramp* values.
- Display panel: Navigate as follows - *Stand Alone > Volts Start/Ramp*, and enter the starting voltage and rate of voltage/sec.

Stand Alone Menu	Parameter Description	Parameter Value	Default
Volt Start <V _{RMS} > Ramp <V _{RMS} /sec>	Sets start voltage and voltage rate to provide output voltage to connected loads.	0 –480 V _{RMS} 3 - 6000 V _{RMS} /sec	0 3000

Frequency

The Frequency setting establishes the normal operating MicroTurbine frequency.

- CRMS: From the menu, select *Settings > Stand Alone Voltage and Frequency Settings*, and enter the desired *Frequency* value.
- Display panel: Navigate as follows - *Stand Alone > Frequency*.

Stand Alone Menu	Parameter Description	Parameter Value	Default
Frequency <Hz>	Sets the initial nominal output frequency.	10 – 60 Hz	60

Under Frequency

The system will initiate a shut down if the frequency falls below this selected value for a specified time period. Under Frequency delay is the time period allowed for the Under Frequency value to remain below the set limit.

- CRMS: From the menu, select *Settings > Stand Alone Voltage and Frequency Settings*, and enter the desired *Under Frequency* value.
- Display panel: Navigate as follows - *Stand Alone > Under Frequency*.

Stand Alone Menu	Parameter Description	Parameter Value	Default
Under Frequency <Hz> <sec>	Sets lower limit for operating frequency for a selected time period.	45 – 65 Hz 0.0 – 10.00 sec	59.3 0.09

Over Frequency

The system will initiate a shut down if the frequency exceeds this selected value for a specified time period. Over Frequency delay is the time period allowed for the Over Frequency value to exceed the set limit.

- CRMS: From the menu, select *Settings > Stand Alone Voltage and Frequency Settings*, and enter the desired *Over Frequency* value.
- Display panel: Navigate as follows - *Stand Alone > Over Frequency*.

Stand Alone Menu	Parameter Description	Parameter Value	Default
Over Frequency <Hz> <sec>	Sets upper limit for operating frequency for a selected time period.	45 – 65 Hz 0.0 – 10.00 sec	60.5 0.09

Soft Start Frequency

Soft Start Frequency establishes the starting frequency. When the output contactor closes, the system will provide demanded current at this starting frequency and immediately begin increasing the frequency up to the nominal frequency.

Ramp Rate Hertz per Second establishes the rate of frequency increase. When the output contactor closes, the system will provide demanded current at the starting frequency and immediately begin increasing the output frequency at this rate.

- CRMS: From the menu, select *Settings > Stand Alone Voltage and Frequency Settings*, and enter the desired *Frequency Start* and *Frequency Ramp* values.
- Display panel: Navigate as follows - *Stand Alone > Freq Start/Ramp*, and enter the starting frequency and rate of frequency/sec.

Stand Alone Menu	Parameter Description	Parameter Value	Default
Freq Start <Hz> Ramp <Hz /sec>	Sets start frequency and frequency rate of change to connected loads.	0 – 60 Hz 0 – 2000 Hz	0 2000

Capstone Technical Information

If questions arise regarding Stand Alone operation for your Capstone MicroTurbine, please contact Capstone Turbine Technical Support for assistance and information.

Capstone Technical Support

Toll Free Telephone: (877) 282-8966

Service Telephone: (818) 407-3600 • Fax: (818) 734-1080

E-mail: service@capstoneturbine.com

Capstone Technical Support (Japan)

Service Telephone: (818) 407-3700 • Fax: (818) 734-1080

E-mail: servicejapan@capstoneturbine.com

Capstone Turbine Corporation

21211 Nordhoff Street • Chatsworth, CA 91311 • USA

Telephone: (818) 734-5300 • Fax: (818) 734-5320

Website: www.microturbine.com